



# Membrane Diffusers & Air Header Systems



**WITKOWITZ**

ENVI

# WITKOWITZ ENVI a.s.

- Design and engineering of steel tanks, wastewater treatment plants, biogas plants and storages for liquid and mineral fertilizers or AdBlue
- Processing of technical-economic studies within the investment construction
- Energy services with guaranteed savings, energy audit
- Design, production, assembly, service and reconstruction of WWTP
- Optimal technology solution for specific input wastewater parameters



## Cooperation of WITKOWITZ ENVI a.s. and OTT GROUP

- Long-term cooperation related to quality of aeration systems
- Optimal solutions for industrial and municipal WWTP HYDROWIT
- Easy assembly and disassembly of individual parts of the systems
- High efficiency of aeration of the flowing medium inside the tank
- Variability of technical solutions





# AirREX® Air Header System

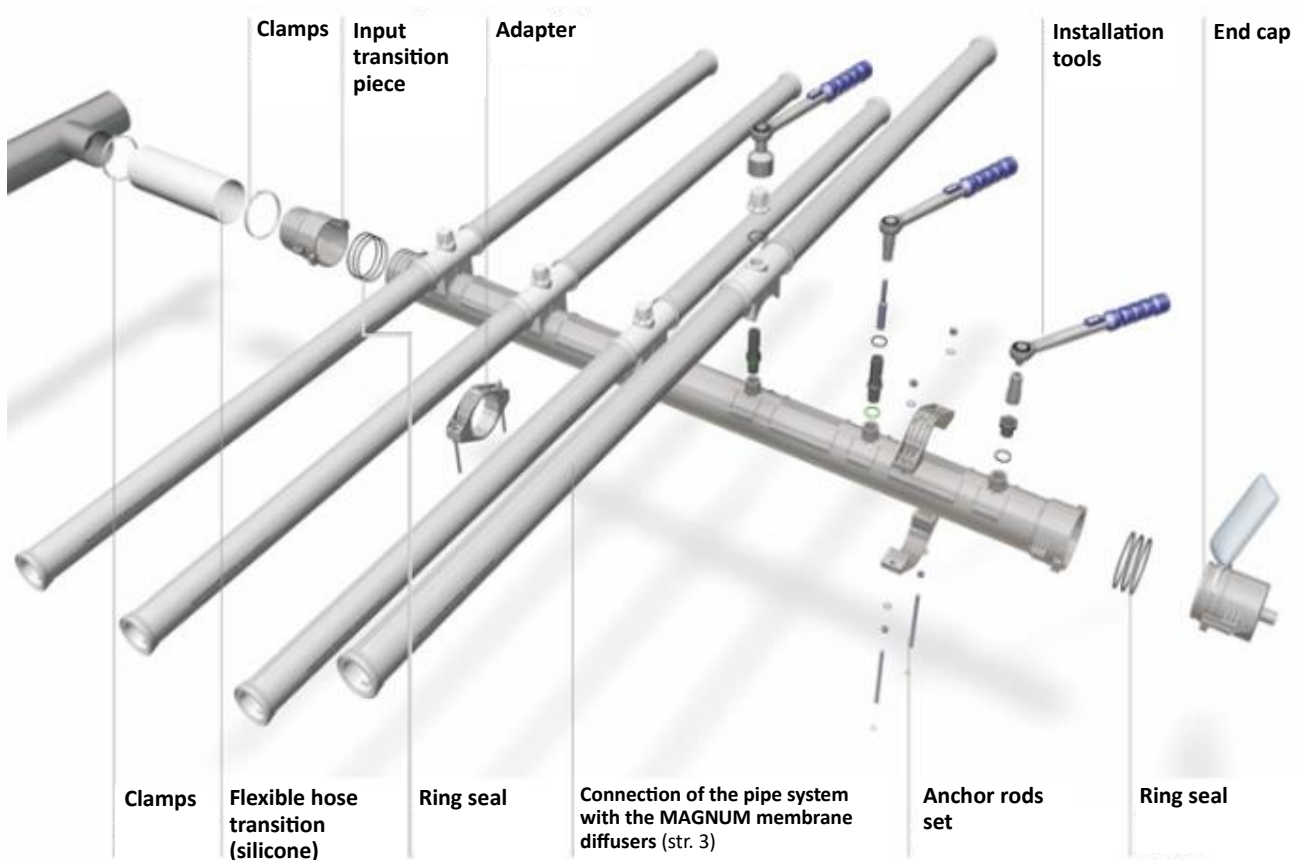

## Simple assembly in three steps

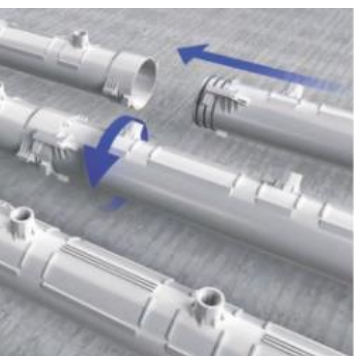

Approx. 2 m long AirREX® modules can be assembled quickly and safely into the branches of the pipeline.

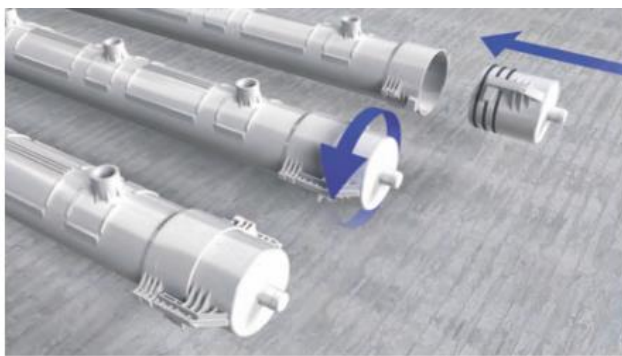

An integrated end cap at the end of each branch allows a cost-friendly connection of the drainage pipe.

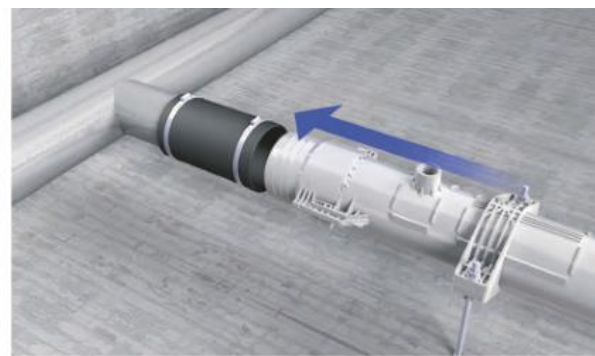

AirREX® transition pieces are made in nominal diameter DN 50 – 100. Simple connection to existing pipeline system is therefore possible.

## Advantages of AirREX® Air Header System

- No pipewelding, coupling or adhesive required during installation
- Different connection dimensions are available to connect the air supply
- Long life and recyclability
- Reduced transport and crane costs based on compact packaging dimensions and low weight

# MAGNUM® Tube Diffusers

The MAGNUM® diffusers are characterized by easy and quick installation, as well as their high quality. Due to their high efficiency, long service life and investment costs are spent economically and sustainably.



## End cap

Made of stainless steel.  
At both ends of the membrane below the cuff.

## Slot

Membrane MAGNUM® diffusers are available with different dimensions and connections. Installation is possible on both square or circular piping.

## One-piece polypropylene body

The MAGNUM® carrier tube is made by pressing from recyclable, environmentally friendly polypropylene.

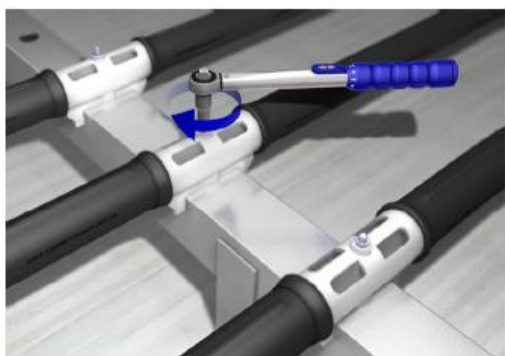

## CLIP IN

The MAGNUM® diffuser can be installed very easily by connecting with CLIP IN connectors.



## Perforation

High perforation provides an uniform aeration for each possible application, in connection with five available perforation lengths.

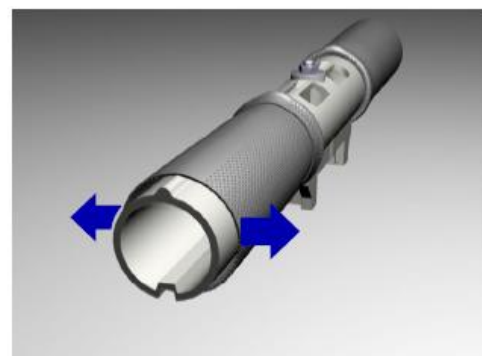

## Air flow

The one-piece design of the MAGNUM® diffuser has an effect on the uniform air flow to the distribution on the underside of the carrier.

- Useful diffuser length: 1 000, 1 500 and 2 000 mm
- High quality membranes for a wide range of applications
- Easy and quick to installation for CLIP IN connectors – up to 250 pcs per hour
- Various solutions for square and circular pipes
- Environmentally friendly polyethylene support pipe
- Only one connection hole needed

# STANDARD Tube Diffuser

Each membrane diffuser undergoes rigorous quality control.

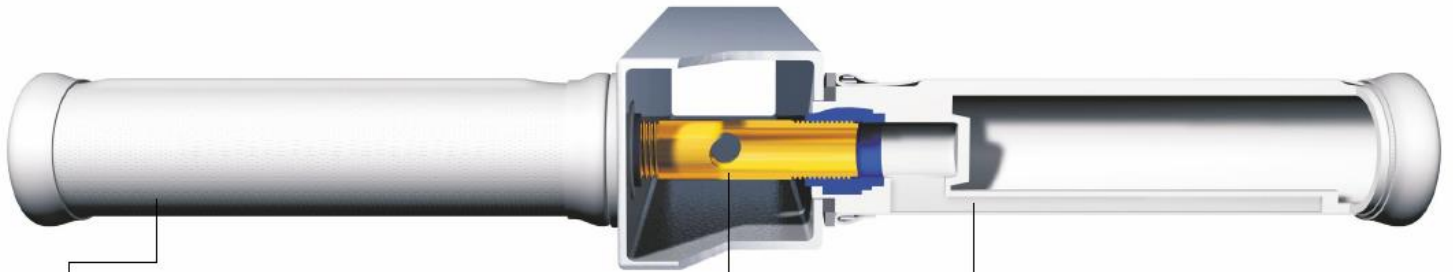

## Membrane without ripple

The patent design ensures that the membrane surface doesn't ripple during the intermittent air supply.

## Double threaded connectors

The diffusers are connected to a tubular bolt with a strong double brass thread (possibly stainless steel). The connectors serve as an air supply and are therefore fitted with holes.

## Polypropylene tube

This tube is a sprayed product from recyclable polypropylene. The structure and shape make the diffuser a unique product.

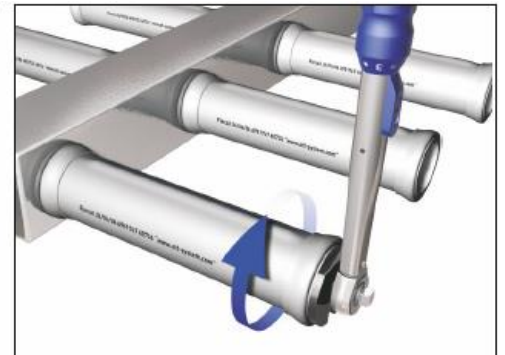
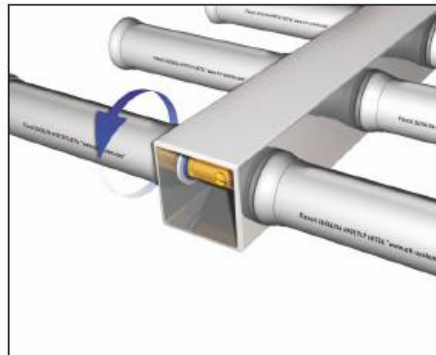
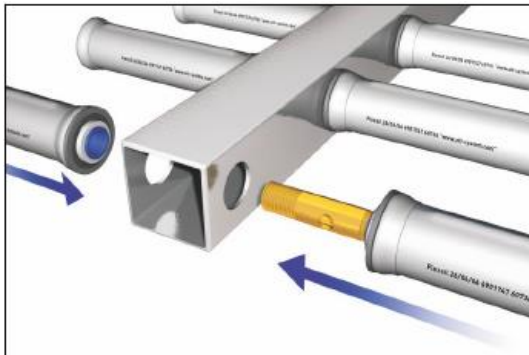

## STANDARD diffuser connection

A 3/4" internal thread of solid POM plastic is connected to the thread on the connector.

The STANDARD diffuser is manufactured in two types:

1. For outlet openings with a diameter of 45 mm
2. For outlet openings with a diameter of 40 mm

Connecting adapters are available for other outlet openings and for circular pipeline.

- **Useful diffuser length: 500, 750 and 1 000 mm (total length is 34 mm longer)**
- **High quality membranes for a wide range of applications**
- **Easy and quick to install**
- **Compatible also with other systems**
- **Environmentally friendly polyethylene support pipe**
- **Continuous air flow even on the underside of the pipe**

# D-REX<sup>®</sup> Disc Diffuser

## Dimensions and specification

Outer Ø	Surface area of membrane	Height	Connection thread	Weight	Max. load
275 mm	Ø 265 mm A = 0,055 m <sup>2</sup>	45 mm	3/4 internal BSP thread	641 g	10 Nm <sup>3</sup> /h

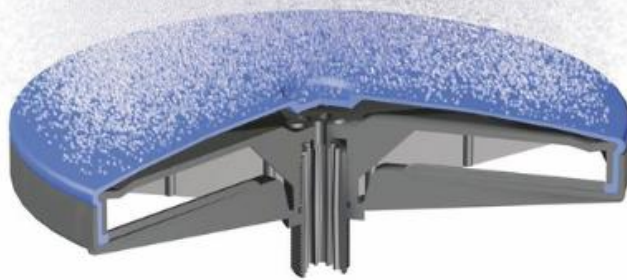

In many applications, 9" diffusers can replace the significantly more expensive 12" diffusers

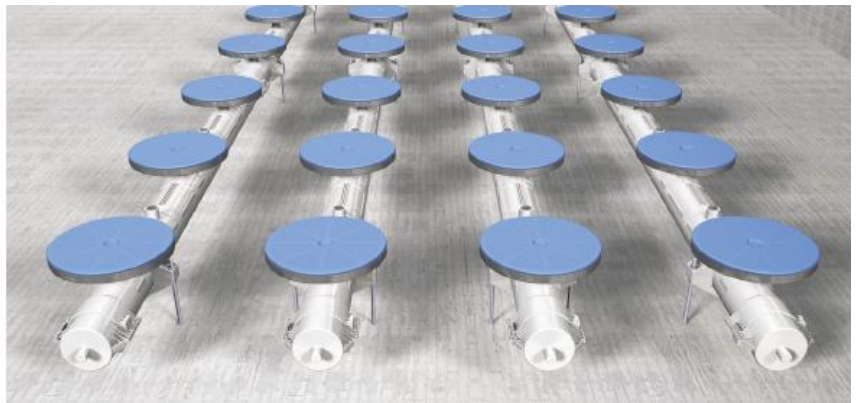
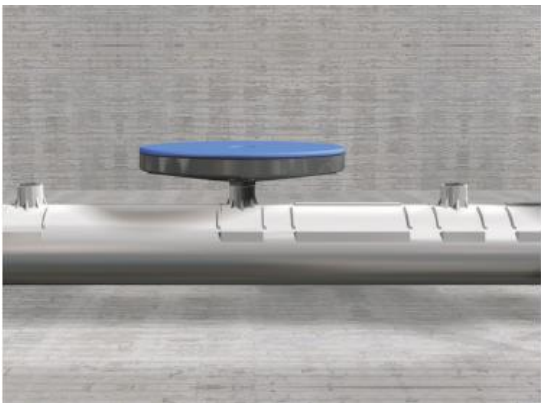

Due to the frameless support structure, it is possible to increase the active area of the membrane. The larger surface area in combination with the uniform degassing of the membrane allows up to 20 % higher output.

The 9" disc diffusers can be mounted on stainless steel, PVC, plastic and OTT AirREX<sup>®</sup> pipe modules. There is a connection extension for each type of disc diffuser.

- **Temperature of the compressed air at the transfer point up to 120 °C**
- **Effective degassing at each element load levels**
- **High material resistance**
- **Great UV stability**
- **Robust construction**
- **Simple and quick assembly**



# Membranes for OTT diffusers

## FLEXNORM®



## Bioresistant and Rugged

FLEXNORM® membranes are highly recommended for use in municipal wastewaters. Made from high quality raw materials including a biologically resistant plasticizer, they provide long service life even at air temperatures up to 80 °C (176 °F).

## FLEXSIL®



## Efficient and durable

FLEXSIL® membranes are recommended for use with challenging wastewaters as well as in aeration systems requiring high efficiency and long service life. FLEXSIL® membranes are suitable for applications at high submersion depths, in heavily polluted wastewaters and at compressed air temperatures up to 100 °C (212 °F). Made of plasticizer-free materials of construction, they are not subject to embrittlement and are fully resistant to bioslime, a wide range of chemicals as well as oils and greases.

## FLEXSIL+®

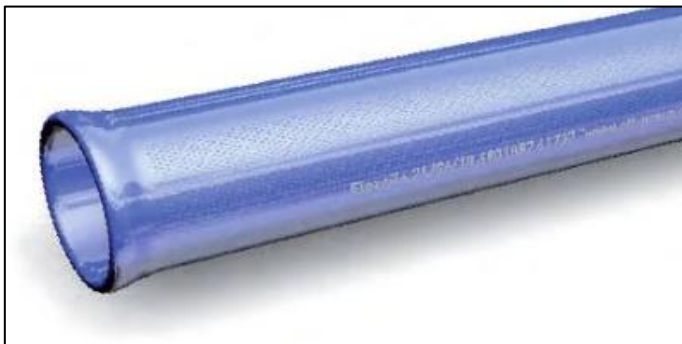

## Soft membrane

FLEXSIL+® membranes have the same excellent properties as FLEXSIL® membranes plus improved adhesion resistance. The result is a reduced level of pollution or fouling, thereby minimising the increase in pressure drop and maximising the efficiency of the aeration process.

## FLEXLON®



## Etalon for disc diffusers

FLEXLON® is OTT's own membrane material. Reliable also at temperatures above 100 °C (212 °F) with very good chemical resistance. It is also long-term reliable when used for aeration in municipal and industrial waters.

## OTT diffusers for aeration in WWTP HYDROWIT



### WITKOWITZ ENVI a.s.

Design, engineering and assembly of WWTP HYDROWIT

- Short construction time
- Minimal and easy maintenance
- Low requirements for construction work
- Technology layout variability
- Warranty and post-warranty service
- Easy disposal after at the end of life period



WITKOWITZ ENVI a.s.  
Ruská 1142/30, 703 00  
Ostrava-Vítkovice  
Czech Republic

+420 724 937 609  
envi@witkowitz.cz  
www.witkowitz-envi.cz